

All Traffic Data Services
Wheat Ridge, CO 80033

Site Code: 11
Station ID: 11
US40 N.O. CR5

NB

Start Time	Bikes	Cars & Trailers	2 Axle Long	Buses	2 Axle 6 Tire	3 Axle Single	4 Axle Single	<5 Axl Double	5 Axle Double	>6 Axl Double	<6 Axl Multi	6 Axle Multi	>6 Axl Multi	Total
07/13/19	0	32	7	0	6	0	0	1	1	0	0	0	0	47
01:00	0	24	2	0	3	0	0	3	0	0	0	0	0	32
02:00	0	6	0	0	2	0	0	0	0	0	0	0	0	8
03:00	0	3	2	0	2	0	0	0	0	0	0	0	0	7
04:00	0	10	2	0	0	0	0	2	0	0	0	0	0	14
05:00	0	23	7	1	11	0	0	2	0	0	0	0	0	44
06:00	0	83	19	0	20	0	0	8	0	0	0	0	0	130
07:00	1	155	27	2	54	1	0	10	0	0	0	0	0	250
08:00	7	301	56	1	55	1	0	8	2	0	0	0	0	431
09:00	7	449	65	2	39	0	0	11	0	0	0	0	0	573
10:00	8	460	58	1	25	0	0	5	0	0	0	0	0	557
11:00	11	469	56	4	32	2	0	7	0	0	0	0	0	581
12 PM	16	446	62	0	29	1	0	6	0	0	0	0	0	560
13:00	11	496	55	2	36	2	0	5	1	0	0	0	0	608
14:00	20	502	52	2	33	0	0	5	0	0	0	0	0	614
15:00	7	472	72	1	41	0	0	7	0	0	0	0	0	600
16:00	4	408	65	1	38	0	0	12	0	0	0	0	0	528
17:00	3	362	48	1	37	0	0	13	0	0	0	0	0	464
18:00	4	300	43	2	25	0	0	4	0	0	0	0	0	378
19:00	2	195	26	1	24	0	0	0	0	0	0	0	0	248
20:00	1	171	22	0	20	0	0	6	0	0	0	0	0	220
21:00	1	195	29	0	29	0	0	4	0	0	0	0	0	258
22:00	1	93	15	2	10	0	0	5	0	0	0	0	0	126
23:00	0	39	7	0	7	0	0	0	0	0	0	0	0	53
Day Total	104	5694	797	23	578	7	0	124	4	0	0	0	0	7331
Percent	1.4%	77.7%	10.9%	0.3%	7.9%	0.1%	0.0%	1.7%	0.1%	0.0%	0.0%	0.0%	0.0%	
AM Peak	11:00	11:00	09:00	11:00	08:00	11:00		09:00	08:00					11:00
Vol.	11	469	65	4	55	2		11	2					581
PM Peak	14:00	14:00	15:00	13:00	15:00	13:00		17:00	13:00					14:00
Vol.	20	502	72	2	41	2		13	1					614
Grand Total	104	5694	797	23	578	7	0	124	4	0	0	0	0	7331
Percent	1.4%	77.7%	10.9%	0.3%	7.9%	0.1%	0.0%	1.7%	0.1%	0.0%	0.0%	0.0%	0.0%	

All Traffic Data Services
Wheat Ridge, CO 80033

Site Code: 11
Station ID: 11
US40 N.O. CR5

SB

Start Time	Bikes	Cars & Trailers	2 Axle Long	Buses	2 Axle 6 Tire	3 Axle Single	4 Axle Single	<5 Axl Double	5 Axle Double	>6 Axl Double	<6 Axl Multi	6 Axle Multi	>6 Axl Multi	Total
07/13/19	0	15	1	0	0	0	0	0	0	0	0	0	0	16
01:00	0	9	1	0	1	0	0	0	1	0	0	0	0	12
02:00	0	8	1	0	0	0	0	0	0	0	0	0	0	9
03:00	0	5	0	0	0	0	0	0	1	0	0	0	0	6
04:00	0	14	2	0	2	0	0	0	1	0	0	0	0	19
05:00	1	50	6	0	9	1	0	2	0	0	0	0	0	69
06:00	0	94	12	1	6	0	0	1	0	1	0	0	0	115
07:00	2	211	30	1	25	0	0	1	1	0	0	0	0	271
08:00	3	298	39	1	24	0	0	8	0	0	0	0	0	373
09:00	5	353	49	3	17	2	0	5	0	0	0	0	0	434
10:00	1	453	48	0	26	0	0	7	3	0	0	0	0	538
11:00	8	496	51	2	30	2	0	5	1	0	0	0	0	595
12 PM	11	394	38	1	27	0	0	3	2	0	0	0	0	476
13:00	9	430	47	1	23	3	0	5	0	0	0	0	0	518
14:00	15	446	40	1	20	1	0	9	1	0	0	0	0	533
15:00	5	496	58	0	34	0	0	7	0	0	0	0	0	600
16:00	14	492	52	1	26	1	0	8	0	0	0	0	0	594
17:00	7	486	56	2	29	0	0	3	0	0	0	0	0	583
18:00	5	397	52	4	19	0	0	6	1	0	0	0	0	484
19:00	0	319	33	0	10	0	0	3	0	0	0	0	0	365
20:00	0	217	24	0	9	0	0	0	1	0	0	0	0	251
21:00	0	149	13	1	6	0	0	3	1	0	0	0	0	173
22:00	0	107	12	0	4	0	0	1	1	0	0	0	0	125
23:00	0	62	2	0	1	0	0	0	1	0	0	0	0	66
Day Total	86	6001	667	19	348	10	0	77	16	1	0	0	0	7225
Percent	1.2%	83.1%	9.2%	0.3%	4.8%	0.1%	0.0%	1.1%	0.2%	0.0%	0.0%	0.0%	0.0%	
AM Peak	11:00	11:00	11:00	09:00	11:00	09:00		08:00	10:00	06:00				11:00
Vol.	8	496	51	3	30	2		8	3	1				595
PM Peak	14:00	15:00	15:00	18:00	15:00	13:00		14:00	12:00					15:00
Vol.	15	496	58	4	34	3		9	2					600
Grand Total	86	6001	667	19	348	10	0	77	16	1	0	0	0	7225
Percent	1.2%	83.1%	9.2%	0.3%	4.8%	0.1%	0.0%	1.1%	0.2%	0.0%	0.0%	0.0%	0.0%	

All Traffic Data Services
Wheat Ridge, CO 80033

Site Code: 12
Station ID: 12
US40 N.O. FIRE STATION

NB

Start Time	Bikes	Cars & Trailers	2 Axle Long	Buses	2 Axle 6 Tire	3 Axle Single	4 Axle Single	<5 Axl Double	5 Axle Double	>6 Axl Double	<6 Axl Multi	6 Axle Multi	>6 Axl Multi	Total
07/13/19	0	48	3	0	1	0	0	0	1	0	0	0	0	53
01:00	0	34	3	0	1	0	0	0	2	0	0	0	0	40
02:00	0	14	2	0	1	0	0	0	0	0	0	0	0	17
03:00	0	7	1	0	1	0	0	1	0	0	0	0	0	10
04:00	0	13	1	0	0	0	0	0	1	0	0	0	0	15
05:00	0	37	7	0	1	0	0	0	0	0	0	0	0	45
06:00	0	92	15	0	1	2	0	1	0	0	0	0	0	111
07:00	0	220	30	0	2	1	0	1	2	1	0	0	0	257
08:00	8	419	57	0	6	2	0	2	2	0	1	0	0	497
09:00	10	555	52	1	4	2	0	2	1	0	0	0	0	627
10:00	8	582	36	1	3	0	0	1	0	0	0	0	0	631
11:00	12	543	47	1	2	0	0	1	1	0	1	0	0	608
12 PM	16	673	65	1	4	1	0	3	0	0	0	1	0	764
13:00	12	733	51	1	5	1	0	4	1	1	0	0	0	809
14:00	16	658	40	1	6	0	1	1	0	0	0	2	0	725
15:00	13	702	66	2	2	1	1	5	2	2	0	1	0	797
16:00	13	697	63	1	1	1	1	2	0	1	0	0	0	780
17:00	6	638	58	2	5	1	0	4	1	0	0	0	0	715
18:00	4	516	45	3	8	0	0	1	1	0	0	0	0	578
19:00	6	387	25	0	4	0	0	0	1	0	0	0	0	423
20:00	2	331	22	0	3	0	0	0	3	0	0	0	0	361
21:00	0	233	12	0	4	0	0	0	0	0	0	0	0	249
22:00	1	147	12	1	6	0	0	1	0	0	0	0	0	168
23:00	0	85	9	0	3	0	0	0	0	0	0	0	0	97
Day Total	127	8364	722	15	74	12	3	30	19	5	2	4	0	9377
Percent	1.4%	89.2%	7.7%	0.2%	0.8%	0.1%	0.0%	0.3%	0.2%	0.1%	0.0%	0.0%	0.0%	
AM Peak	11:00	10:00	08:00	09:00	08:00	06:00		08:00	01:00	07:00	08:00			10:00
Vol.	12	582	57	1	6	2		2	2	1	1			631
PM Peak	12:00	13:00	15:00	18:00	18:00	12:00	14:00	15:00	20:00	15:00		14:00		13:00
Vol.	16	733	66	3	8	1	1	5	3	2		2		809
Grand Total	127	8364	722	15	74	12	3	30	19	5	2	4	0	9377
Percent	1.4%	89.2%	7.7%	0.2%	0.8%	0.1%	0.0%	0.3%	0.2%	0.1%	0.0%	0.0%	0.0%	

All Traffic Data Services
Wheat Ridge, CO 80033

Site Code: 12
Station ID: 12
US40 N.O. FIRE STATION

SB

Start Time	Bikes	Cars & Trailers	2 Axle Long	Buses	2 Axle 6 Tire	3 Axle Single	4 Axle Single	<5 Axl Double	5 Axle Double	>6 Axl Double	<6 Axl Multi	6 Axle Multi	>6 Axl Multi	Total
07/13/19	0	10	0	0	0	0	0	0	0	0	0	0	0	10
01:00	0	6	1	0	0	0	0	0	1	0	0	0	0	8
02:00	0	9	0	0	2	0	0	0	0	0	0	0	0	11
03:00	0	5	1	0	0	0	0	0	1	0	0	0	0	7
04:00	0	15	3	0	0	0	0	0	1	0	0	0	0	19
05:00	0	48	8	0	8	0	0	3	2	0	0	0	0	69
06:00	2	139	25	0	15	0	0	2	0	1	0	0	0	184
07:00	0	283	46	2	37	0	0	3	1	0	0	0	0	372
08:00	4	447	57	1	27	1	0	5	1	0	0	0	0	543
09:00	4	508	55	1	15	1	0	6	1	0	0	0	0	591
10:00	4	632	57	0	19	1	0	4	1	0	0	0	0	718
11:00	12	595	57	0	15	6	0	2	0	0	0	0	0	687
12 PM	9	673	58	1	14	0	0	1	3	0	0	0	0	759
13:00	7	625	64	1	19	0	0	1	0	0	0	0	0	717
14:00	13	547	44	2	12	2	0	1	1	0	0	0	0	622
15:00	15	523	45	1	19	1	0	3	1	0	0	0	0	608
16:00	28	651	71	1	18	1	0	7	0	0	0	0	0	777
17:00	10	679	62	2	25	0	0	4	0	0	0	0	0	782
18:00	8	478	53	1	28	1	0	4	1	0	0	0	0	574
19:00	1	388	43	0	15	0	0	0	0	0	0	0	0	447
20:00	4	306	38	8	11	0	0	1	1	0	0	0	0	369
21:00	0	256	24	1	13	1	0	7	1	0	0	0	0	303
22:00	0	131	13	1	9	1	0	2	2	0	0	0	0	159
23:00	0	47	5	0	1	0	0	0	1	0	0	0	0	54
Day Total	121	8001	830	23	322	16	0	56	20	1	0	0	0	9390
Percent	1.3%	85.2%	8.8%	0.2%	3.4%	0.2%	0.0%	0.6%	0.2%	0.0%	0.0%	0.0%	0.0%	
AM Peak	11:00	10:00	08:00	07:00	07:00	11:00		09:00	05:00	06:00				10:00
Vol.	12	632	57	2	37	6		6	2	1				718
PM Peak	16:00	17:00	16:00	20:00	18:00	14:00		16:00	12:00					17:00
Vol.	28	679	71	8	28	2		7	3					782
Grand Total	121	8001	830	23	322	16	0	56	20	1	0	0	0	9390
Percent	1.3%	85.2%	8.8%	0.2%	3.4%	0.2%	0.0%	0.6%	0.2%	0.0%	0.0%	0.0%	0.0%	



(303) 216-2439
www.alltrafficdata.net

Location: 1 US 40 & CR 5 AM
Date: Saturday, July 13, 2019
Peak Hour: 09:00 AM - 10:00 AM
Peak 15-Minutes: 09:45 AM - 10:00 AM

Peak Hour - All Vehicles

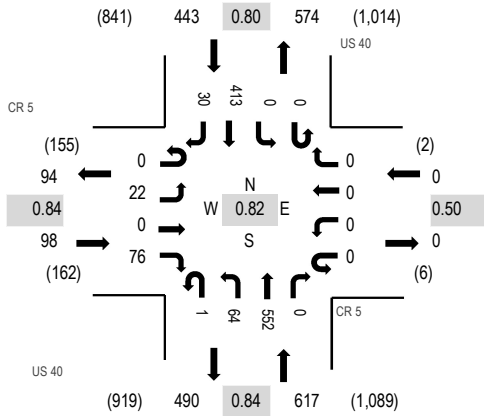

Peak Hour - Pedestrians/Bicycles on Crosswalk

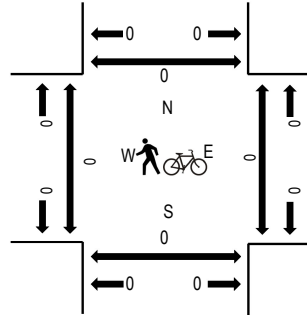

Note: Total study counts contained in parentheses.

Traffic Counts

Interval Start Time	CR 5 Eastbound				CR 5 Westbound				US 40 Northbound				US 40 Southbound				Total	Rolling Hour	Pedestrian Crossings				
	U-Turn	Left	Thru	Right	U-Turn	Left	Thru	Right	U-Turn	Left	Thru	Right	U-Turn	Left	Thru	Right			West	East	South	North	
8:00 AM	0	3	0	10	0	0	0	0	0	1	7	95	1	0	0	80	2	199	936	0	0	0	0
8:15 AM	1	2	0	8	0	0	0	0	0	0	15	90	2	1	0	85	4	208	965	0	0	0	0
8:30 AM	0	3	0	12	0	1	0	0	0	0	9	104	1	0	0	95	4	229	1,021	0	0	0	0
8:45 AM	0	9	0	16	0	1	0	0	0	0	13	133	1	0	1	120	6	300	1,107	0	0	0	0
9:00 AM	0	8	0	8	0	0	0	0	0	0	15	110	0	0	0	84	3	228	1,158	0	0	0	0
9:15 AM	0	4	0	20	0	0	0	0	0	0	9	129	0	0	0	93	9	264		0	0	0	0
9:30 AM	0	3	0	26	0	0	0	0	1	16	153	0	0	0	109	7	315		0	0	0	0	
9:45 AM	0	7	0	22	0	0	0	0	0	24	160	0	0	0	127	11	351		0	0	0	0	
Count Total	1	39	0	122	0	2	0	0	2	108	974	5	1	1	793	46	2,094		0	0	0	0	
Peak Hour	0	22	0	76	0	0	0	0	1	64	552	0	0	0	413	30	1,158		0	0	0	0	



(303) 216-2439
www.alltrafficdata.net

Location: 2 US 40 & CR 8 AM
Date: Saturday, July 13, 2019
Peak Hour: 09:00 AM - 10:00 AM
Peak 15-Minutes: 09:45 AM - 10:00 AM

Peak Hour - All Vehicles

Peak Hour - Pedestrians/Bicycles on Crosswalk

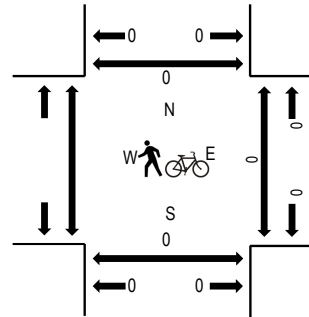
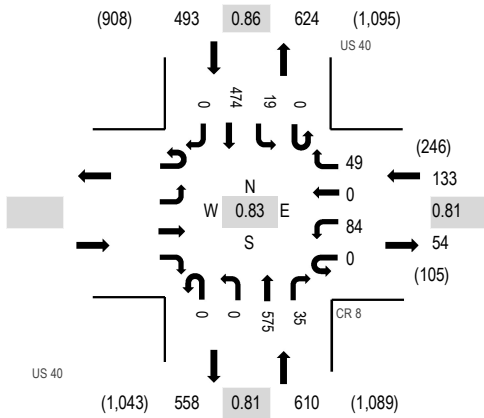

Note: Total study counts contained in parentheses.

Traffic Counts

Interval Start Time	CR 8				US 40				US 40				Total	Rolling Hour	Pedestrian Crossings						
	Eastbound		Westbound		Northbound		Southbound		U-Turn	Left	Thru	Right			West	East	South	North			
	U-Turn	Left	Thru	Right	U-Turn	Left	Thru	Right					U-Turn	Left					Thru	Right	
8:00 AM					0	13	0	6	1	0	94	9	0	4	86	0	213	1,007	0	0	0
8:15 AM					0	24	0	8	0	0	105	8	0	2	91	0	238	1,048	0	0	0
8:30 AM					0	24	0	4	0	0	112	10	0	5	98	0	253	1,088	0	0	0
8:45 AM					0	21	0	13	0	0	129	11	0	2	127	0	303	1,165	0	0	0
9:00 AM					0	23	0	9	0	0	112	12	0	4	94	0	254	1,236	0	0	0
9:15 AM					0	18	0	10	0	0	127	8	0	6	109	0	278		0	0	0
9:30 AM					0	13	0	19	0	0	156	6	0	5	131	0	330		0	0	0
9:45 AM					0	30	0	11	0	0	180	9	0	4	140	0	374		0	0	0
Count Total					0	166	0	80	1	0	1,015	73	0	32	876	0	2,243		0	0	0
Peak Hour					0	84	0	49	0	0	575	35	0	19	474	0	1,236		0	0	0



(303) 216-2439
www.alltrafficdata.net

Location: 3 US 40 & EISENHOWER DR AM

Date: Saturday, July 13, 2019

Peak Hour: 09:00 AM - 10:00 AM

Peak 15-Minutes: 09:45 AM - 10:00 AM

Peak Hour - All Vehicles

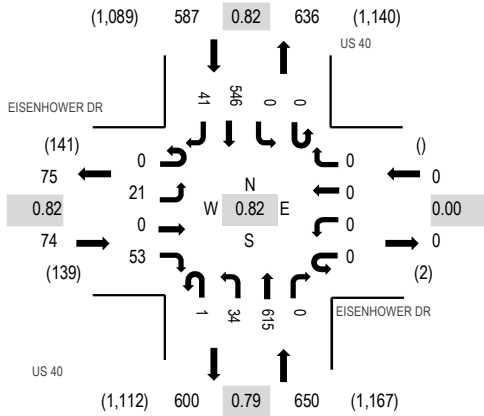

Note: Total study counts contained in parentheses.

Peak Hour - Pedestrians/Bicycles on Crosswalk

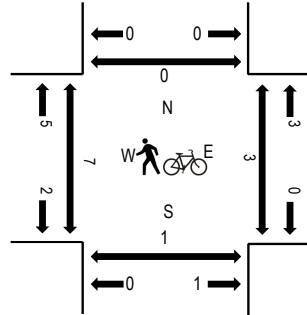

Traffic Counts

Interval Start Time	EISENHOWER DR Eastbound				EISENHOWER DR Westbound				US 40 Northbound				US 40 Southbound				Total	Rolling Hour	Pedestrian Crossings				
	U-Turn	Left	Thru	Right	U-Turn	Left	Thru	Right	U-Turn	Left	Thru	Right	U-Turn	Left	Thru	Right			West	East	South	North	
8:00 AM	0	9	0	8	0	0	0	0	0	1	5	103	0	0	1	86	8	221	1,084	3	1	0	0
8:15 AM	0	3	0	9	0	0	0	0	0	0	11	116	0	1	1	122	1	264	1,132	0	1	0	0
8:30 AM	0	6	0	5	0	0	0	0	2	8	8	126	0	0	0	119	6	272	1,152	0	1	1	0
8:45 AM	0	9	0	16	0	0	0	0	0	0	14	131	0	0	0	144	13	327	1,237	0	0	0	0
9:00 AM	0	8	0	10	0	0	0	0	1	8	8	122	0	0	0	111	9	269	1,311	0	0	0	0
9:15 AM	0	7	0	11	0	0	0	0	0	0	5	131	0	0	0	119	11	284		0	1	0	0
9:30 AM	0	4	0	17	0	0	0	0	0	0	10	167	0	0	0	150	9	357		0	2	0	0
9:45 AM	0	2	0	15	0	0	0	0	0	0	11	195	0	0	0	166	12	401		0	0	0	0
Count Total	0	48	0	91	0	0	0	0	4	72	72	1,091	0	1	2	1,017	69	2,395		3	6	1	0
Peak Hour	0	21	0	53	0	0	0	0	1	34	34	615	0	0	0	546	41	1,311		0	3	0	0



(303) 216-2439
www.alltrafficdata.net

Location: 4 US 40 & BYERS AVE AM
Date: Saturday, July 13, 2019
Peak Hour: 09:00 AM - 10:00 AM
Peak 15-Minutes: 09:45 AM - 10:00 AM

Peak Hour - All Vehicles

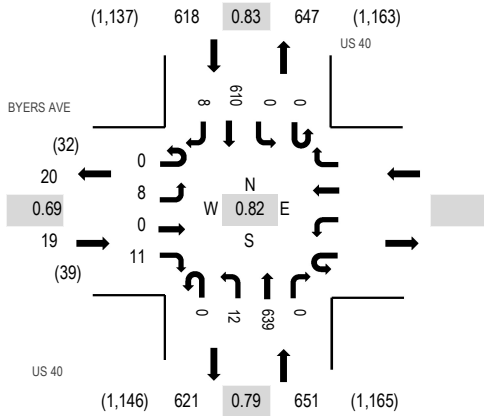

Note: Total study counts contained in parentheses.

Peak Hour - Pedestrians/Bicycles on Crosswalk

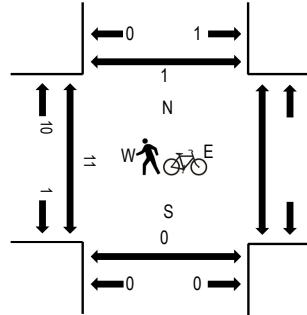

Traffic Counts

Interval Start Time	BYERS AVE Eastbound				Westbound			US 40 Northbound				US 40 Southbound				Total	Rolling Hour	Pedestrian Crossings			
	U-Turn	Left	Thru	Right	U-Turn	Left	Thru	Right	U-Turn	Left	Thru	Right	U-Turn	Left	Thru			Right	West	East	South
8:00 AM	0	2	0	1					0	1	108	0	0	0	98	1	211	1,053	0	0	0
8:15 AM	0	2	0	4					0	1	123	0	0	0	128	1	259	1,096	2	0	0
8:30 AM	0	0	0	2					0	2	137	0	0	0	126	1	268	1,115	0	0	1
8:45 AM	0	4	0	5					0	2	140	0	0	0	161	3	315	1,209	0	0	0
9:00 AM	0	3	0	0					0	2	131	0	0	0	118	0	254	1,288	0	0	0
9:15 AM	0	4	0	1					0	2	132	0	0	0	136	3	278		1	0	1
9:30 AM	0	1	0	7					0	3	176	0	0	0	172	3	362		3	0	0
9:45 AM	0	0	0	3					0	5	200	0	0	0	184	2	394		1	0	0
Count Total	0	16	0	23					0	18	1,147	0	0	0	1,123	14	2,341		7	0	2
Peak Hour	0	8	0	11					0	12	639	0	0	0	610	8	1,288		5	0	1



(303) 216-2439
www.alltrafficdata.net

Location: 5 US 40 & CLAYTON AVE AM

Date: Saturday, July 13, 2019

Peak Hour: 09:00 AM - 10:00 AM

Peak 15-Minutes: 09:45 AM - 10:00 AM

Peak Hour - All Vehicles

Peak Hour - Pedestrians/Bicycles on Crosswalk

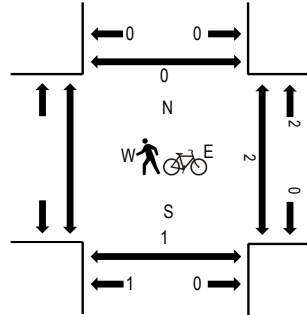
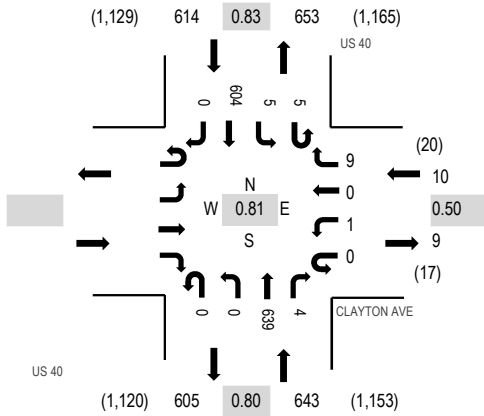

Note: Total study counts contained in parentheses.

Traffic Counts

Interval Start Time	CLAYTON AVE				US 40				US 40				Total	Rolling Hour	Pedestrian Crossings							
	Eastbound		Westbound		Northbound		Southbound		U-Turn	Left	Thru	Right			West	East	South	North				
8:00 AM					0	1	0	2					0	1					0	104	2	1
8:15 AM					0	1	0	0	0	0	0	123	0	1	0	126	0	251	1,079	0	0	0
8:30 AM					0	2	0	3	0	0	0	136	1	0	2	125	0	269	1,098	0	0	0
8:45 AM					0	0	0	1	0	0	0	141	2	0	1	161	0	306	1,184	0	0	0
9:00 AM					0	0	0	1	0	0	0	132	2	0	0	118	0	253	1,267	0	0	0
9:15 AM					0	0	0	1	0	0	0	132	0	2	2	133	0	270		0	1	0
9:30 AM					0	1	0	3	0	0	0	177	0	0	2	172	0	355		2	0	0
9:45 AM					0	0	0	4	0	0	0	198	2	3	1	181	0	389		0	0	0
Count Total					0	5	0	15	1	0	0	1,143	9	7	8	1,114	0	2,302		3	1	0
Peak Hour					0	1	0	9	0	0	0	639	4	5	5	604	0	1,267		2	1	0



(303) 216-2439
www.alltrafficdata.net

Location: 6 US 40 & CR 72 AM
Date: Saturday, July 13, 2019
Peak Hour: 09:00 AM - 10:00 AM
Peak 15-Minutes: 09:45 AM - 10:00 AM

Peak Hour - All Vehicles

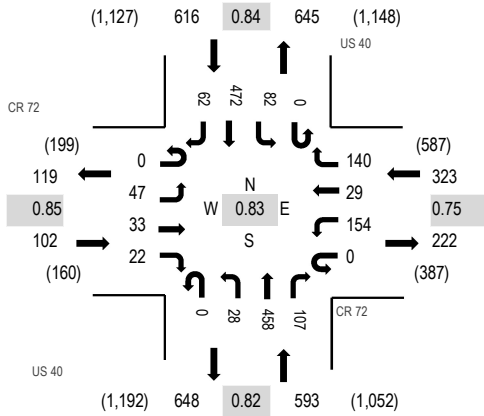

Peak Hour - Pedestrians/Bicycles on Crosswalk

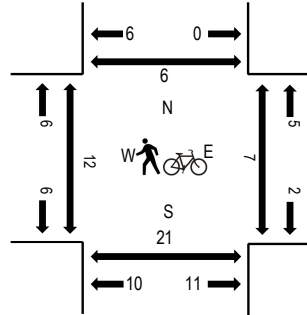

Note: Total study counts contained in parentheses.

Traffic Counts

Interval Start Time	CR 72 Eastbound				CR 72 Westbound				US 40 Northbound				US 40 Southbound				Total	Rolling Hour	Pedestrian Crossings			
	U-Turn	Left	Thru	Right	U-Turn	Left	Thru	Right	U-Turn	Left	Thru	Right	U-Turn	Left	Thru	Right			West	East	South	North
8:00 AM	0	9	4	0	0	28	4	20	0	4	80	16	0	17	74	8	264	1,292	0	0	0	0
8:15 AM	0	6	8	4	0	17	4	31	0	5	89	12	0	16	96	12	300	1,379	0	0	5	0
8:30 AM	0	3	4	5	0	44	4	23	0	4	106	17	0	16	101	9	336	1,428	0	0	0	0
8:45 AM	0	4	6	5	0	49	4	36	0	6	96	24	0	25	121	16	392	1,535	1	0	3	1
9:00 AM	0	11	10	3	0	33	6	36	0	4	94	30	0	9	103	12	351	1,634	1	2	3	0
9:15 AM	0	17	6	3	0	39	6	32	0	11	81	22	0	19	98	15	349		4	2	1	3
9:30 AM	0	7	8	7	0	30	7	27	0	6	146	28	0	23	137	17	443		1	2	5	0
9:45 AM	0	12	9	9	0	52	10	45	0	7	137	27	0	31	134	18	491		0	0	9	0
Count Total	0	69	55	36	0	292	45	250	0	47	829	176	0	156	864	107	2,926		7	6	26	4
Peak Hour	0	47	33	22	0	154	29	140	0	28	458	107	0	82	472	62	1,634		6	6	18	3



(303) 216-2439
www.alltrafficdata.net

Location: 7 US 40 & JOHNS DR AM
Date: Saturday, July 13, 2019
Peak Hour: 09:00 AM - 10:00 AM
Peak 15-Minutes: 09:45 AM - 10:00 AM

Peak Hour - All Vehicles

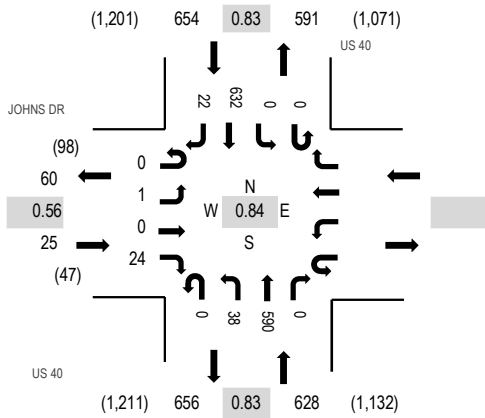

Peak Hour - Pedestrians/Bicycles on Crosswalk

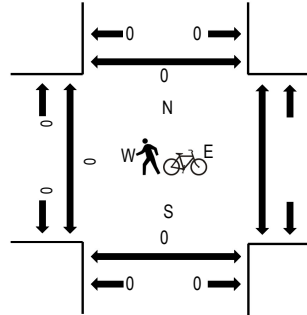

Note: Total study counts contained in parentheses.

Traffic Counts

Interval Start Time	JOHNS DR Eastbound				Westbound			US 40 Northbound			US 40 Southbound				Total	Rolling Hour	Pedestrian Crossings			
	U-Turn	Left	Thru	Right	U-Turn	Left	Thru Right	U-Turn	Left	Thru Right	U-Turn	Left	Thru	Right			West	East	South	North
8:00 AM	0	0	0	2				0	10	102	0	0	0	104	4	222	1,073	0	0	0
8:15 AM	0	0	0	7				0	6	105	0	0	0	115	1	234	1,128	0	0	0
8:30 AM	0	0	0	9				0	1	139	0	0	0	148	4	301	1,160	0	0	0
8:45 AM	0	0	0	4				0	7	134	0	0	0	166	5	316	1,234	0	0	0
9:00 AM	0	0	0	6				0	11	116	0	0	0	141	3	277	1,307	0	0	0
9:15 AM	0	1	0	4				0	6	118	0	0	0	133	4	266		0	0	0
9:30 AM	0	0	0	12				0	11	177	0	0	0	172	3	375		0	0	0
9:45 AM	0	0	0	2				0	10	179	0	0	0	186	12	389		0	0	0
Count Total	0	1	0	46				0	62	1,070	0	0	0	1,165	36	2,380		0	0	0
Peak Hour	0	1	0	24				0	38	590	0	0	0	632	22	1,307		0	0	0



(303) 216-2439
www.alltrafficdata.net

Location: 8 US 40 & OLD VICTORY RD AM
Date: Saturday, July 13, 2019
Peak Hour: 09:00 AM - 10:00 AM
Peak 15-Minutes: 09:45 AM - 10:00 AM

Peak Hour - All Vehicles

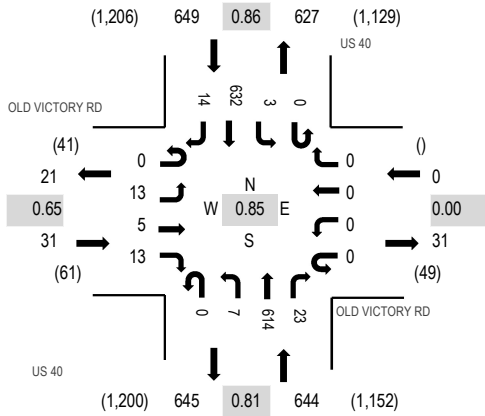

Peak Hour - Pedestrians/Bicycles on Crosswalk

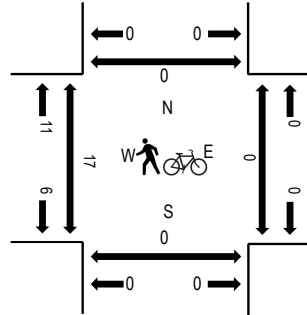

Note: Total study counts contained in parentheses.

Traffic Counts

Interval Start Time	OLD VICTORY RD Eastbound				OLD VICTORY RD Westbound				US 40 Northbound			US 40 Southbound				Total	Rolling Hour	Pedestrian Crossings				
	U-Turn	Left	Thru	Right	U-Turn	Left	Thru	Right	U-Turn	Left	Thru	Right	U-Turn	Left	Thru			Right	West	East	South	North
8:00 AM	0	5	1	4	0	0	0	0	0	2	106	6	0	0	109	0	233	1,095	0	0	0	0
8:15 AM	0	1	1	2	0	0	0	0	0	1	109	2	0	0	114	7	237	1,143	1	0	0	0
8:30 AM	0	2	0	4	0	0	0	0	0	1	139	4	0	0	147	5	302	1,175	1	0	0	0
8:45 AM	0	6	1	3	0	0	0	0	0	2	134	2	0	1	172	2	323	1,256	1	0	0	0
9:00 AM	0	7	1	5	0	0	0	0	0	0	118	3	0	0	142	5	281	1,324	0	0	0	0
9:15 AM	0	2	0	3	0	0	0	0	0	4	125	6	0	1	126	2	269		1	0	0	0
9:30 AM	0	1	2	1	0	0	0	0	0	1	183	6	0	1	185	3	383		0	0	0	0
9:45 AM	0	3	2	4	0	0	0	0	0	2	188	8	0	1	179	4	391		3	0	0	0
Count Total	0	27	8	26	0	0	0	0	0	13	1,102	37	0	4	1,174	28	2,419		7	0	0	0
Peak Hour	0	13	5	13	0	0	0	0	0	7	614	23	0	3	632	14	1,324		4	0	0	0



(303) 216-2439
www.alltrafficdata.net

Location: 9 US 40 & FIRE STATION ACCESS AM

Date: Saturday, July 13, 2019

Peak Hour: 09:00 AM - 10:00 AM

Peak 15-Minutes: 09:45 AM - 10:00 AM

Peak Hour - All Vehicles

Peak Hour - Pedestrians/Bicycles on Crosswalk

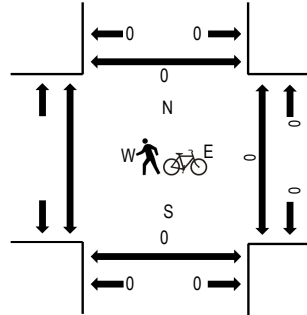
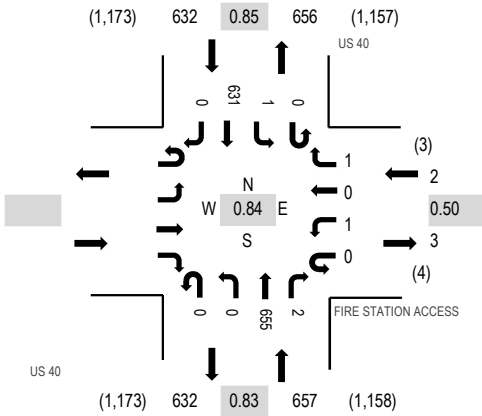

Note: Total study counts contained in parentheses.

Traffic Counts

Interval Start Time	FIRE STATION ACCESS				US 40				US 40				Total	Rolling Hour	Pedestrian Crossings						
	Eastbound		Westbound		Northbound		Southbound		U-Turn	Left	Thru	Right			West	East	South	North			
	U-Turn	Left	Thru	Right	U-Turn	Left	Thru	Right					U-Turn	Left					Thru	Right	
8:00 AM					0	0	0	0	0	0	111	1	0	0	105	0	217	1,043	0	0	0
8:15 AM					0	0	0	1	0	0	109	0	0	0	119	0	229	1,100	0	0	0
8:30 AM					0	0	0	0	0	0	145	0	0	0	148	0	293	1,149	0	0	0
8:45 AM					0	0	0	0	0	0	135	0	0	0	169	0	304	1,213	0	0	0
9:00 AM					0	1	0	0	0	0	126	1	0	0	146	0	274	1,291	0	0	0
9:15 AM					0	0	0	0	0	0	143	0	0	0	135	0	278		0	0	0
9:30 AM					0	0	0	1	0	0	190	0	0	1	165	0	357		0	0	0
9:45 AM					0	0	0	0	0	0	196	1	0	0	185	0	382		0	0	0
Count Total					0	1	0	2	0	0	1,155	3	0	1	1,172	0	2,334		0	0	0
Peak Hour					0	1	0	1	0	0	655	2	0	1	631	0	1,291		0	0	0



(303) 216-2439
www.alltrafficdata.net

Location: 10 US 40 & RENDEZVOUS RD AM
Date: Saturday, July 13, 2019
Peak Hour: 09:00 AM - 10:00 AM
Peak 15-Minutes: 09:45 AM - 10:00 AM

Peak Hour - All Vehicles

Peak Hour - Pedestrians/Bicycles on Crosswalk

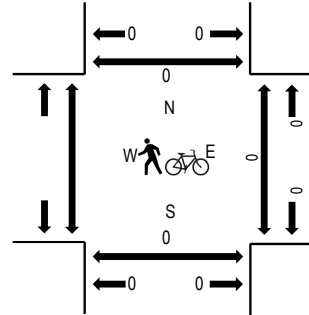
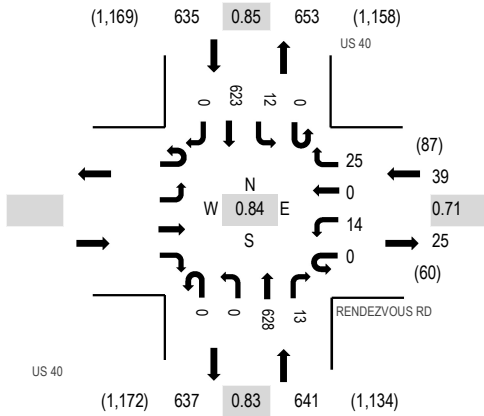

Note: Total study counts contained in parentheses.

Traffic Counts

Interval Start Time	RENDEZVOUS RD				US 40 Northbound				US 40 Southbound				Total	Rolling Hour	Pedestrian Crossings						
	Eastbound		Westbound		Northbound		Southbound		West	East	South	North									
	U-Turn	Left	Thru	Right	U-Turn	Left	Thru	Right	U-Turn	Left	Thru	Right									
8:00 AM					0	1	0	8	0	0	106	1	0	4	101	0	221	1,075	0	0	0
8:15 AM					0	3	0	7	0	0	99	3	0	5	109	0	226	1,132	0	0	2
8:30 AM					0	8	0	4	0	0	142	7	0	3	149	0	313	1,192	0	0	0
8:45 AM					0	5	0	12	0	0	127	8	0	4	159	0	315	1,237	0	0	0
9:00 AM					0	2	0	2	0	0	122	3	0	3	146	0	278	1,315	0	0	0
9:15 AM					0	5	0	7	0	0	138	3	0	1	132	0	286		0	0	0
9:30 AM					0	3	0	7	0	0	180	2	0	6	160	0	358		0	0	0
9:45 AM					0	4	0	9	0	0	188	5	0	2	185	0	393		0	0	0
Count Total					0	31	0	56	0	0	1,102	32	0	28	1,141	0	2,390		0	0	2
Peak Hour					0	14	0	25	0	0	628	13	0	12	623	0	1,315		0	0	0



(303) 216-2439
www.alltrafficdata.net

Location: 2 US 40 & CR 8 Noon

Date: Saturday, July 13, 2019

Peak Hour: 01:00 PM - 02:00 PM

Peak 15-Minutes: 01:30 PM - 01:45 PM

Peak Hour - All Vehicles

Peak Hour - Pedestrians/Bicycles on Crosswalk

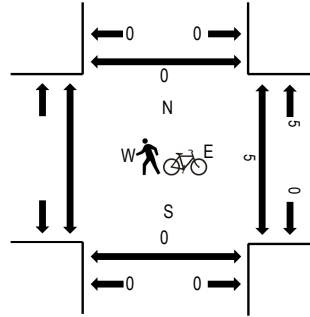
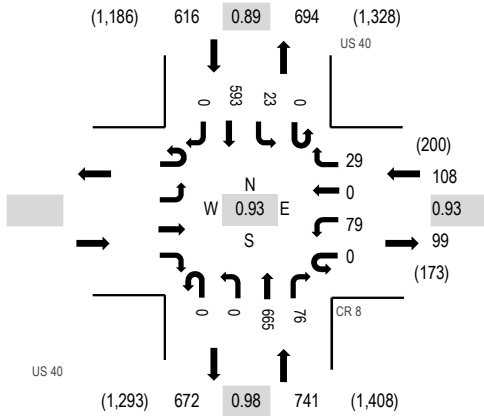

Note: Total study counts contained in parentheses.

Traffic Counts

Interval Start Time	CR 8				US 40				US 40				Total	Rolling Hour	Pedestrian Crossings						
	Eastbound		Westbound		Northbound		Southbound		U-Turn	Left	Thru	Right			West	East	South	North			
	U-Turn	Left	Thru	Right	U-Turn	Left	Thru	Right					U-Turn	Left					Thru	Right	
12:00 PM					0	17	0	5	0	0	135	14	0	2	119	0	292	1,329	0	0	0
12:15 PM					0	19	0	5	0	0	147	20	0	8	164	0	363	1,391	0	0	0
12:30 PM					0	19	0	6	0	0	157	10	0	8	139	0	339	1,389	0	0	0
12:45 PM					0	18	0	3	1	0	175	8	1	4	125	0	335	1,443	0	0	0
1:00 PM					0	23	0	4	0	0	157	23	0	3	144	0	354	1,465	0	0	0
1:15 PM					0	21	0	6	0	0	172	17	0	10	135	0	361		0	0	0
1:30 PM					0	17	0	12	0	0	173	17	0	6	168	0	393		0	0	0
1:45 PM					0	18	0	7	0	0	163	19	0	4	146	0	357		0	0	0
Count Total					0	152	0	48	1	0	1,279	128	1	45	1,140	0	2,794		0	0	0
Peak Hour					0	79	0	29	0	0	665	76	0	23	593	0	1,465		0	0	0



(303) 216-2439
www.alltrafficdata.net

Location: 3 US 40 & EISENHOWER DR Noon

Date: Saturday, July 13, 2019

Peak Hour: 01:00 PM - 02:00 PM

Peak 15-Minutes: 01:45 PM - 02:00 PM

Peak Hour - All Vehicles

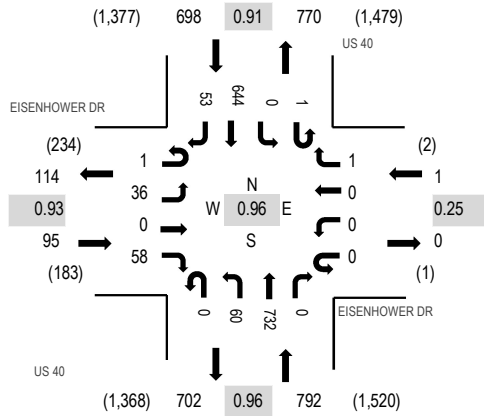

Note: Total study counts contained in parentheses.

Peak Hour - Pedestrians/Bicycles on Crosswalk

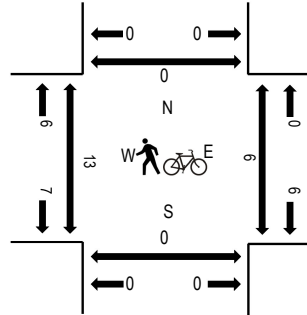

Traffic Counts

Interval Start Time	EISENHOWER DR Eastbound				EISENHOWER DR Westbound				US 40 Northbound				US 40 Southbound				Total	Rolling Hour	Pedestrian Crossings				
	U-Turn	Left	Thru	Right	U-Turn	Left	Thru	Right	U-Turn	Left	Thru	Right	U-Turn	Left	Thru	Right			West	East	South	North	
12:00 PM	0	4	0	8	0	0	0	0	0	0	16	155	0	3	0	134	15	335	1,496	0	0	0	0
12:15 PM	0	7	0	16	0	0	0	0	0	0	11	166	0	3	0	163	17	383	1,555	0	0	0	0
12:30 PM	0	7	0	20	0	0	0	0	0	0	12	161	0	1	0	162	19	382	1,550	0	0	0	0
12:45 PM	0	8	0	18	0	0	0	1	0	0	14	192	1	1	0	145	16	396	1,569	0	0	0	0
1:00 PM	0	7	0	17	0	0	0	0	0	0	16	185	0	0	0	158	11	394	1,586	3	1	0	0
1:15 PM	1	7	0	11	0	0	0	0	0	0	12	197	0	0	0	138	12	378		0	0	0	0
1:30 PM	0	9	0	19	0	0	0	0	0	0	17	169	0	1	0	165	21	401		2	1	0	0
1:45 PM	0	13	0	11	0	0	0	1	0	0	15	181	0	0	0	183	9	413		2	0	0	0
Count Total	1	62	0	120	0	0	0	2	0	0	113	1,406	1	9	0	1,248	120	3,082		7	2	0	0
Peak Hour	1	36	0	58	0	0	0	1	0	0	60	732	0	1	0	644	53	1,586		7	2	0	0



(303) 216-2439
www.alltrafficdata.net

Location: 4 US 40 & BYERS AVE Noon

Date: Saturday, July 13, 2019

Peak Hour: 01:00 PM - 02:00 PM

Peak 15-Minutes: 01:45 PM - 02:00 PM

Peak Hour - All Vehicles

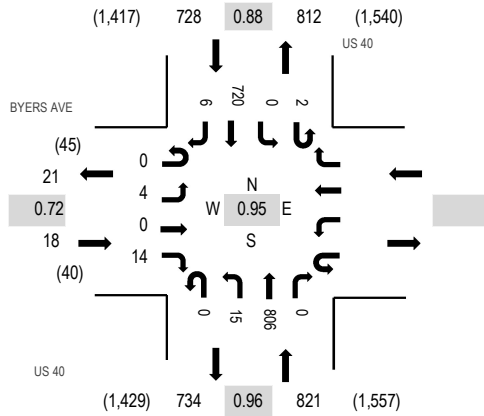

Peak Hour - Pedestrians/Bicycles on Crosswalk

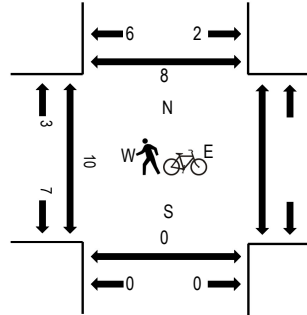

Note: Total study counts contained in parentheses.

Traffic Counts

Interval Start Time	BYERS AVE Eastbound				Westbound			US 40 Northbound				US 40 Southbound				Total	Rolling Hour	Pedestrian Crossings			
	U-Turn	Left	Thru	Right	U-Turn	Left	Thru	Right	U-Turn	Left	Thru	Right	U-Turn	Left	Thru			Right	West	East	South
12:00 PM	0	1	0	2					0	3	169	0	0	0	142	1	318	1,447	1	0	4
12:15 PM	0	2	0	7					0	4	175	0	0	0	181	2	371	1,521	1	0	0
12:30 PM	0	4	0	3					0	5	171	0	0	0	190	4	377	1,523	1	0	0
12:45 PM	0	2	0	1					0	5	204	0	0	0	169	0	381	1,535	1	0	0
1:00 PM	0	2	0	5					0	2	206	0	1	0	176	0	392	1,567	0	0	0
1:15 PM	0	0	0	2					0	5	211	0	0	0	154	1	373		1	0	1
1:30 PM	0	2	0	4					0	5	188	0	1	0	185	4	389		1	0	0
1:45 PM	0	0	0	3					0	3	201	0	0	0	205	1	413		0	0	1
Count Total	0	13	0	27					0	32	1,525	0	2	0	1,402	13	3,014		6	0	6
Peak Hour	0	4	0	14					0	15	806	0	2	0	720	6	1,567		2	0	2



(303) 216-2439
www.alltrafficdata.net

Location: 5 US 40 & CLAYTON AVE Noon
Date: Saturday, July 13, 2019
Peak Hour: 01:00 PM - 02:00 PM
Peak 15-Minutes: 01:45 PM - 02:00 PM

Peak Hour - All Vehicles

Peak Hour - Pedestrians/Bicycles on Crosswalk

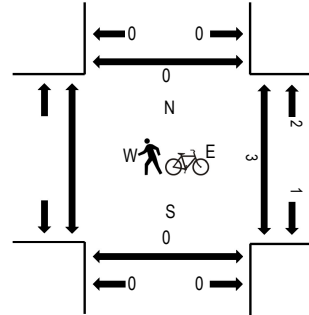
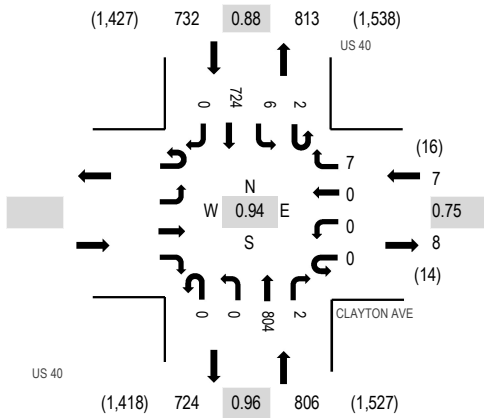

Note: Total study counts contained in parentheses.

Traffic Counts

Interval Start Time	CLAYTON AVE				US 40				US 40				Total	Rolling Hour	Pedestrian Crossings						
	Eastbound		Westbound		Northbound		Southbound		U-Turn	Left	Thru	Right			West	East	South	North			
	U-Turn	Left	Thru	Right	U-Turn	Left	Thru	Right					U-Turn	Left					Thru	Right	
12:00 PM					0	1	0	2	0	0	170	1	0	0	145	0	319	1,425	0	0	0
12:15 PM					0	2	0	1	0	0	175	1	1	0	185	0	365	1,495	0	0	0
12:30 PM					0	1	0	1	0	0	169	0	1	1	191	0	364	1,500	0	0	0
12:45 PM					0	0	0	1	0	0	204	1	0	2	169	0	377	1,511	0	0	0
1:00 PM					0	0	0	1	0	0	207	0	0	0	181	0	389	1,545	0	0	0
1:15 PM					0	0	0	2	0	0	211	0	2	2	153	0	370		0	0	0
1:30 PM					0	0	0	1	0	0	187	1	0	1	185	0	375		0	0	0
1:45 PM					0	0	0	3	0	0	199	1	0	3	205	0	411		0	0	0
Count Total					0	4	0	12	0	0	1,522	5	4	9	1,414	0	2,970		0	0	0
Peak Hour					0	0	0	7	0	0	804	2	2	6	724	0	1,545		0	0	0



(303) 216-2439
www.alltrafficdata.net

Location: 6 US 40 & CR 72 Noon
Date: Saturday, July 13, 2019
Peak Hour: 12:15 PM - 01:15 PM
Peak 15-Minutes: 01:00 PM - 01:15 PM

Peak Hour - All Vehicles

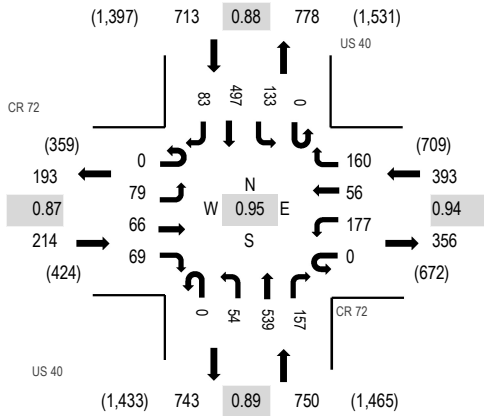

Peak Hour - Pedestrians/Bicycles on Crosswalk

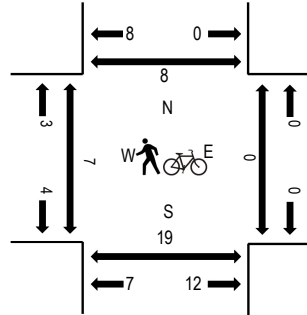

Note: Total study counts contained in parentheses.

Traffic Counts

Interval Start Time	CR 72 Eastbound				CR 72 Westbound				US 40 Northbound				US 40 Southbound				Total	Rolling Hour	Pedestrian Crossings			
	U-Turn	Left	Thru	Right	U-Turn	Left	Thru	Right	U-Turn	Left	Thru	Right	U-Turn	Left	Thru	Right			West	East	South	North
12:00 PM	0	23	14	12	0	37	7	32	0	13	108	34	0	17	109	14	420	1,948	0	0	1	3
12:15 PM	0	15	18	17	0	37	16	41	0	11	122	46	0	38	117	24	502	2,070	3	0	3	0
12:30 PM	0	21	13	19	0	53	13	38	0	12	123	33	0	39	129	19	512	2,047	0	0	0	0
12:45 PM	0	26	19	19	0	47	17	38	0	16	139	30	0	24	122	17	514	2,037	1	0	1	0
1:00 PM	0	17	16	14	0	40	10	43	0	15	155	48	0	32	129	23	542	2,047	0	0	0	0
1:15 PM	0	29	16	13	0	37	13	40	0	13	131	36	0	22	110	19	479		0	0	0	0
1:30 PM	0	19	12	13	0	31	11	34	0	15	141	41	0	28	140	17	502		0	0	4	0
1:45 PM	0	30	17	12	0	30	7	37	0	12	129	42	0	37	146	25	524		0	0	1	1
Count Total	0	180	125	119	0	312	94	303	0	107	1,048	310	0	237	1,002	158	3,995		4	0	10	4
Peak Hour	0	79	66	69	0	177	56	160	0	54	539	157	0	133	497	83	2,070		4	0	4	0



(303) 216-2439
www.alltrafficdata.net

Location: 7 US 40 & JOHNS DR Noon

Date: Saturday, July 13, 2019

Peak Hour: 01:00 PM - 02:00 PM

Peak 15-Minutes: 01:00 PM - 01:15 PM

Peak Hour - All Vehicles

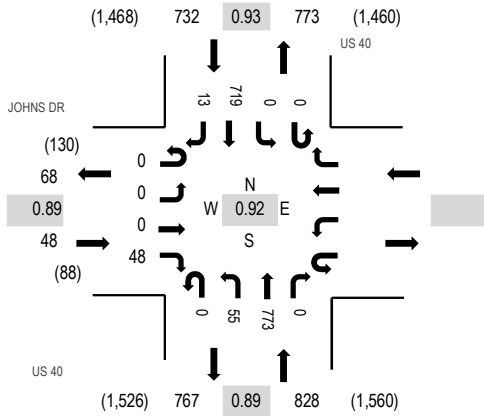

Peak Hour - Pedestrians/Bicycles on Crosswalk

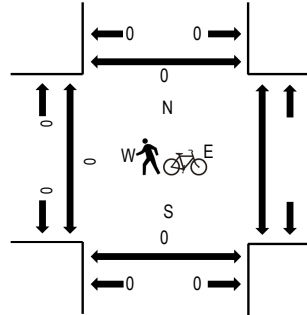

Note: Total study counts contained in parentheses.

Traffic Counts

Interval Start Time	JOHNS DR Eastbound				Westbound			US 40 Northbound			US 40 Southbound				Total	Rolling Hour	Pedestrian Crossings			
	U-Turn	Left	Thru	Right	U-Turn	Left	Thru Right	U-Turn	Left	Thru Right	U-Turn	Left	Thru	Right			West	East	South	North
12:00 PM	0	0	0	15				0	10	163	0	0	0	158	2	348	1,508	0	0	0
12:15 PM	0	0	0	3				0	15	182	0	0	0	174	4	378	1,596	0	0	0
12:30 PM	0	2	0	6				0	13	160	0	0	0	200	6	387	1,589	0	0	0
12:45 PM	0	0	0	14				0	9	180	0	0	0	189	3	395	1,603	0	0	0
1:00 PM	0	0	0	12				0	13	219	0	0	0	184	8	436	1,608	0	0	0
1:15 PM	0	0	0	11				0	18	180	0	0	0	161	1	371		0	0	0
1:30 PM	0	0	0	13				0	10	196	0	0	0	180	2	401		0	0	0
1:45 PM	0	0	0	12				0	14	178	0	0	0	194	2	400		0	0	0
Count Total	0	2	0	86				0	102	1,458	0	0	0	1,440	28	3,116		0	0	0
Peak Hour	0	0	0	48				0	55	773	0	0	0	719	13	1,608		0	0	0



(303) 216-2439
www.alltrafficdata.net

Location: 8 US 40 & OLD VICTORY RD Noon
Date: Saturday, July 13, 2019
Peak Hour: 12:30 PM - 01:30 PM
Peak 15-Minutes: 01:00 PM - 01:15 PM

Peak Hour - All Vehicles

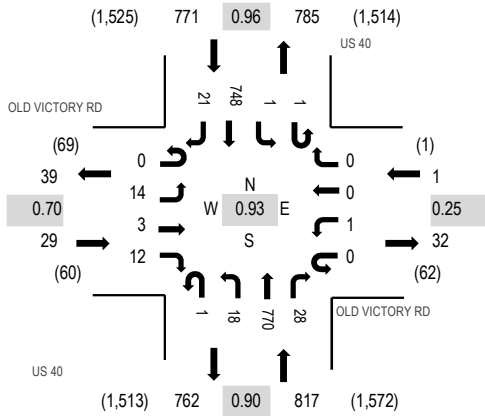

Peak Hour - Pedestrians/Bicycles on Crosswalk

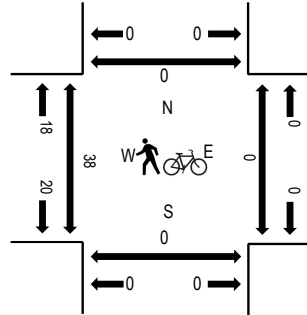

Note: Total study counts contained in parentheses.

Traffic Counts

Interval Start Time	OLD VICTORY RD Eastbound				OLD VICTORY RD Westbound				US 40 Northbound				US 40 Southbound				Total	Rolling Hour	Pedestrian Crossings			
	U-Turn	Left	Thru	Right	U-Turn	Left	Thru	Right	U-Turn	Left	Thru	Right	U-Turn	Left	Thru	Right			West	East	South	North
12:00 PM	0	3	0	6	0	0	0	0	0	3	174	8	0	1	173	6	374	1,551	1	0	0	0
12:15 PM	0	4	0	3	0	0	0	0	0	2	188	9	0	2	175	0	383	1,612	0	0	0	0
12:30 PM	0	0	3	2	0	0	0	0	0	4	177	8	0	0	196	6	396	1,618	1	0	0	0
12:45 PM	0	4	0	4	0	0	0	0	0	4	179	7	1	1	194	4	398	1,609	0	0	0	0
1:00 PM	0	6	0	5	0	0	0	0	0	6	220	1	0	0	191	6	435	1,607	3	0	0	0
1:15 PM	0	4	0	1	0	1	0	0	1	4	194	12	0	0	167	5	389		4	0	0	0
1:30 PM	0	5	0	2	0	0	0	0	0	5	182	4	0	0	183	6	387		0	0	0	0
1:45 PM	0	4	0	4	0	0	0	0	0	5	169	6	0	0	205	3	396		0	0	0	0
Count Total	0	30	3	27	0	1	0	0	1	33	1,483	55	1	4	1,484	36	3,158		9	0	0	0
Peak Hour	0	14	3	12	0	1	0	0	1	18	770	28	1	1	748	21	1,618		8	0	0	0



(303) 216-2439
www.alltrafficdata.net

Location: 9 US 40 & FIRE STATION ACCESS Noon

Date: Saturday, July 13, 2019

Peak Hour: 12:45 PM - 01:45 PM

Peak 15-Minutes: 01:00 PM - 01:15 PM

Peak Hour - All Vehicles

Peak Hour - Pedestrians/Bicycles on Crosswalk

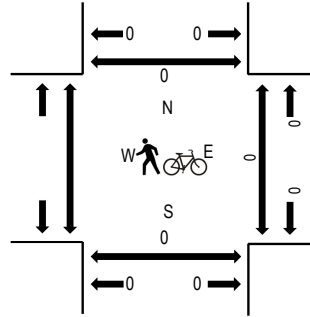
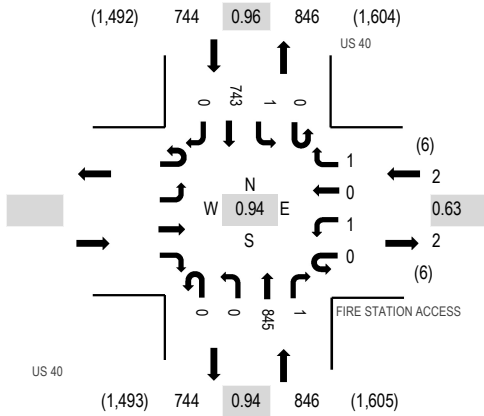

Note: Total study counts contained in parentheses.

Traffic Counts

Interval Start Time	FIRE STATION ACCESS				US 40 Northbound				US 40 Southbound				Total	Rolling Hour	Pedestrian Crossings							
	Eastbound		Westbound		Left		Thru Right		Left		Thru Right				West	East	South	North				
12:00 PM					0	1	0	1	0	0	185	0	0	0	1	188	0	376	1,519	0	0	0
12:15 PM					0	1	0	0	0	0	199	1	0	0	0	172	0	373	1,567	0	0	0
12:30 PM					0	1	0	0	0	0	177	1	0	1	1	193	0	373	1,572	0	0	0
12:45 PM					0	1	0	0	0	0	203	1	0	0	0	192	0	397	1,592	0	0	0
1:00 PM					0	0	0	1	0	0	226	0	0	1	1	196	0	424	1,584	0	0	0
1:15 PM					0	0	0	0	0	0	205	0	0	0	0	173	0	378		0	0	0
1:30 PM					0	0	0	0	0	0	211	0	0	0	0	182	0	393		0	0	0
1:45 PM					0	0	0	0	0	0	196	0	0	0	0	193	0	389		0	0	0
Count Total					0	4	0	2	0	0	1,602	3	0	3	1	1,489	0	3,103		0	0	0
Peak Hour					0	1	0	1	0	0	845	1	0	1	1	743	0	1,592		0	0	0



(303) 216-2439
www.alltrafficdata.net

Location: 2 US 40 & CR 8 PM
Date: Saturday, July 13, 2019
Peak Hour: 04:00 PM - 05:00 PM
Peak 15-Minutes: 04:00 PM - 04:15 PM

Peak Hour - All Vehicles

Peak Hour - Pedestrians/Bicycles on Crosswalk

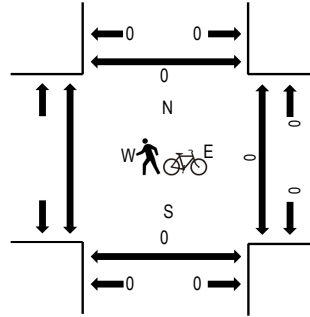
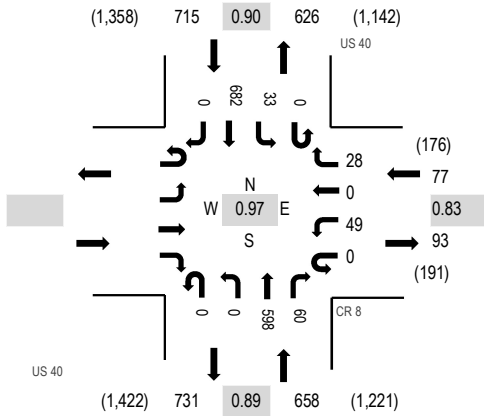

Note: Total study counts contained in parentheses.

Traffic Counts

Interval Start Time	CR 8				US 40				US 40				Total	Rolling Hour	Pedestrian Crossings			
	Eastbound		Westbound		Northbound		Southbound		U-Turn	Left	Thru	Right			West	East	South	North
4:00 PM	0	6	0	7	0	0	174	10					0	10				
4:15 PM	0	11	0	6	0	0	147	23	0	8	165	0	360	1,430	0	0	0	
4:30 PM	0	13	0	6	0	0	156	11	0	8	160	0	354	1,423	0	0	0	
4:45 PM	0	19	0	9	0	0	121	16	0	7	191	0	363	1,394	0	0	0	
5:00 PM	0	28	0	5	0	0	141	12	0	9	158	0	353	1,305	0	0	0	
5:15 PM	0	23	0	6	0	0	147	20	0	4	153	0	353		0	0	0	
5:30 PM	0	12	0	2	0	0	115	22	0	7	167	0	325		0	0	0	
5:45 PM	0	13	0	10	0	0	90	16	0	8	137	0	274		0	0	0	
Count Total	0	125	0	51	0	0	1,091	130	0	61	1,297	0	2,755		0	0	0	
Peak Hour	0	49	0	28	0	0	598	60	0	33	682	0	1,450		0	0	0	



(303) 216-2439
www.alltrafficdata.net

Location: 3 US 40 & EISENHOWER DR PM

Date: Saturday, July 13, 2019

Peak Hour: 04:00 PM - 05:00 PM

Peak 15-Minutes: 04:30 PM - 04:45 PM

Peak Hour - All Vehicles

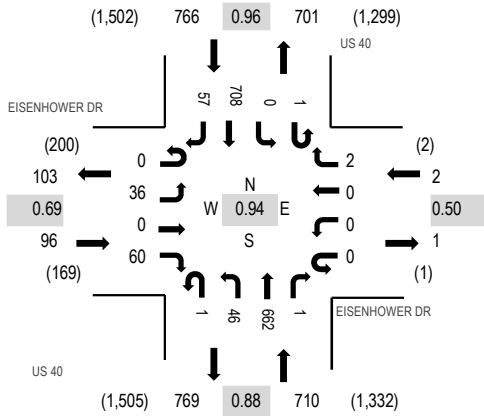

Peak Hour - Pedestrians/Bicycles on Crosswalk

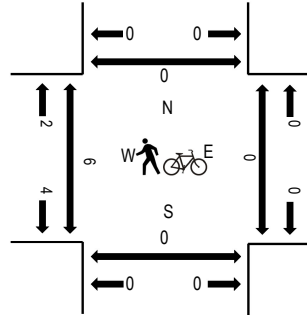

Note: Total study counts contained in parentheses.

Traffic Counts

Interval Start Time	EISENHOWER DR Eastbound				EISENHOWER DR Westbound				US 40 Northbound			US 40 Southbound				Total	Rolling Hour	Pedestrian Crossings					
	U-Turn	Left	Thru	Right	U-Turn	Left	Thru	Right	U-Turn	Left	Thru	Right	U-Turn	Left	Thru			Right	West	East	South	North	
4:00 PM	0	4	0	14	0	0	0	0	0	0	11	190	0	0	0	178	17	414	1,574	0	0	0	0
4:15 PM	0	8	0	16	0	0	0	0	0	0	13	164	0	0	0	158	14	373	1,558	1	0	0	0
4:30 PM	0	17	0	18	0	0	0	1	0	0	13	174	0	1	0	178	16	418	1,571	0	0	0	0
4:45 PM	0	7	0	12	0	0	0	1	1	1	9	134	1	0	0	194	10	369	1,505	1	0	0	0
5:00 PM	0	6	0	10	0	0	0	0	0	0	15	161	0	0	0	196	10	398	1,431	1	0	0	0
5:15 PM	0	12	0	12	0	0	0	0	0	0	15	160	0	1	0	174	12	386		0	0	0	0
5:30 PM	0	7	0	11	0	0	0	0	1	1	9	141	0	1	0	169	13	352		0	0	0	0
5:45 PM	0	3	0	12	0	0	0	0	0	0	14	106	0	0	0	151	9	295		0	0	0	0
Count Total	0	64	0	105	0	0	0	2	2	2	99	1,230	1	3	0	1,398	101	3,005		3	0	0	0
Peak Hour	0	36	0	60	0	0	0	2	1	1	46	662	1	1	0	708	57	1,574		2	0	0	0



(303) 216-2439
www.alltrafficdata.net

Location: 4 US 40 & BYERS AVE

Date: Saturday, July 13, 2019

Peak Hour: 04:30 PM - 05:30 PM

Peak 15-Minutes: 04:30 PM - 04:45 PM

Peak Hour - All Vehicles

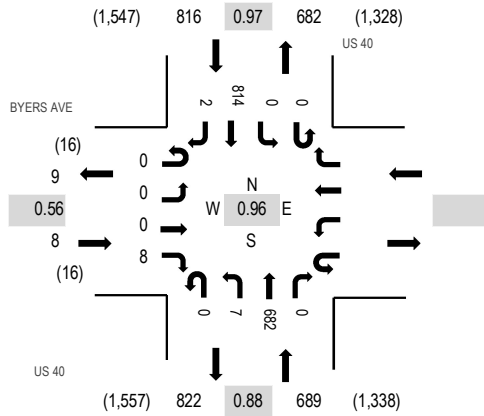

Peak Hour - Pedestrians/Bicycles on Crosswalk

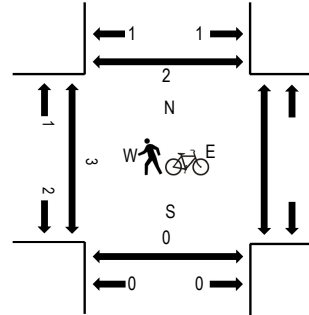

Note: Total study counts contained in parentheses.

Traffic Counts

Interval Start Time	BYERS AVE Eastbound				Westbound			US 40 Northbound				US 40 Southbound				Total	Rolling Hour	Pedestrian Crossings			
	U-Turn	Left	Thru	Right	U-Turn	Left	Thru	Right	U-Turn	Left	Thru	Right	U-Turn	Left	Thru			Right	West	East	South
4:00 PM	0	1	0	3					0	2	200	0	0	0	195	0	401	1,507	1	0	0
4:15 PM	0	1	0	0					0	1	174	0	0	0	178	0	354	1,496	2	0	0
4:30 PM	0	0	0	2					0	1	186	0	0	0	204	1	394	1,513	0	0	1
4:45 PM	0	0	0	2					0	0	148	0	0	0	208	0	358	1,455	0	0	1
5:00 PM	0	0	0	1					0	2	176	0	0	0	210	1	390	1,394	0	0	0
5:15 PM	0	0	0	3					0	4	172	0	0	0	192	0	371		0	0	0
5:30 PM	0	0	0	1					0	1	149	0	0	0	183	2	336		0	0	2
5:45 PM	0	0	0	2					0	1	121	0	0	0	173	0	297		0	0	1
Count Total	0	2	0	14					0	12	1,326	0	0	0	1,543	4	2,901		3	0	5
Peak Hour	0	0	0	8					0	7	682	0	0	0	814	2	1,513		0	0	2



(303) 216-2439
www.alltrafficdata.net

Location: 5 US 40 & CLAYTON AVE PM

Date: Saturday, July 13, 2019

Peak Hour: 04:00 PM - 05:00 PM

Peak 15-Minutes: 04:00 PM - 04:15 PM

Peak Hour - All Vehicles

Peak Hour - Pedestrians/Bicycles on Crosswalk

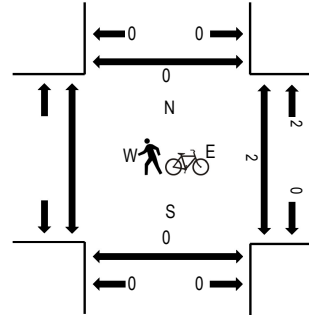
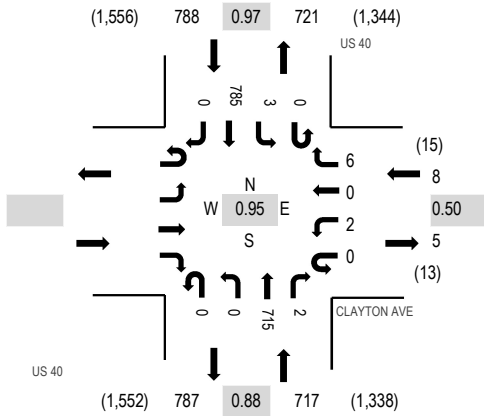

Note: Total study counts contained in parentheses.

Traffic Counts

Interval Start Time	CLAYTON AVE				US 40				US 40				Total	Rolling Hour	Pedestrian Crossings						
	Eastbound		Westbound		Northbound		Southbound		U-Turn	Left	Thru	Right			West	East	South	North			
	U-Turn	Left	Thru	Right	U-Turn	Left	Thru	Right					U-Turn	Left					Thru	Right	
4:00 PM					0	0	0	1	0	0	202	1	0	1	195	0	400	1,513	0	0	0
4:15 PM					0	1	0	3	0	0	178	1	0	0	178	0	361	1,502	0	0	0
4:30 PM					0	0	0	2	0	0	186	0	0	1	206	0	395	1,513	0	0	0
4:45 PM					0	1	0	0	0	0	149	0	0	1	206	0	357	1,455	0	0	0
5:00 PM					0	0	0	1	0	0	177	0	0	1	210	0	389	1,396	0	0	0
5:15 PM					0	1	0	2	0	0	174	1	0	1	193	0	372		0	0	0
5:30 PM					0	0	0	1	0	0	148	1	0	1	186	0	337		0	0	0
5:45 PM					0	1	0	1	0	0	119	1	0	2	174	0	298		0	0	0
Count Total					0	4	0	11	0	0	1,333	5	0	8	1,548	0	2,909		0	0	0
Peak Hour					0	2	0	6	0	0	715	2	0	3	785	0	1,513		0	0	0



(303) 216-2439
www.alltrafficdata.net

Location: 6 US 40 & CR 72 PM
Date: Saturday, July 13, 2019
Peak Hour: 04:00 PM - 05:00 PM
Peak 15-Minutes: 04:00 PM - 04:15 PM

Peak Hour - All Vehicles

Peak Hour - Pedestrians/Bicycles on Crosswalk

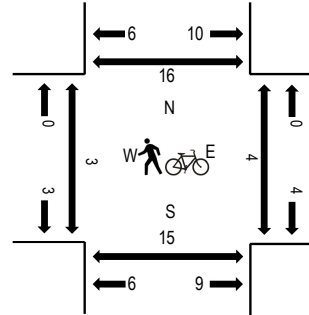
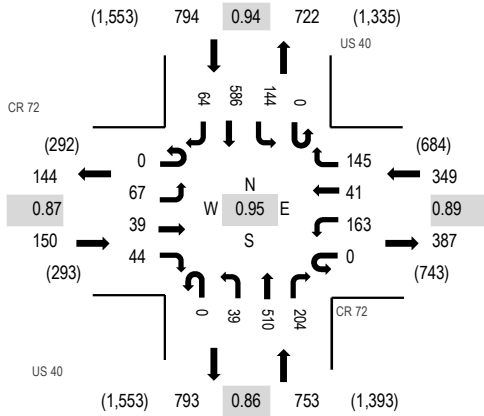

Note: Total study counts contained in parentheses.

Traffic Counts

Interval Start Time	CR 72 Eastbound				CR 72 Westbound				US 40 Northbound			US 40 Southbound				Total	Rolling Hour	Pedestrian Crossings				
	U-Turn	Left	Thru	Right	U-Turn	Left	Thru	Right	U-Turn	Left	Thru	Right	U-Turn	Left	Thru			Right	West	East	South	North
4:00 PM	0	21	13	9	0	33	12	33	0	14	146	58	0	44	137	16	536	2,046	0	0	3	6
4:15 PM	0	14	15	12	0	43	6	43	0	12	119	53	0	32	127	16	492	2,028	0	2	0	2
4:30 PM	0	18	6	10	0	39	9	32	0	4	137	39	0	34	152	19	499	2,011	0	0	5	2
4:45 PM	0	14	5	13	0	48	14	37	0	9	108	54	0	34	170	13	519	1,965	0	2	2	0
5:00 PM	0	14	13	8	0	34	10	31	0	14	132	55	0	29	163	15	518	1,877	0	0	5	0
5:15 PM	0	19	12	11	0	40	9	43	0	10	112	31	0	26	146	16	475		0	0	2	0
5:30 PM	0	14	13	8	0	42	8	38	0	9	92	47	0	36	127	19	453		0	0	1	2
5:45 PM	0	7	11	13	0	39	7	34	0	14	77	47	0	36	129	17	431		2	0	2	1
Count Total	0	121	88	84	0	318	75	291	0	86	923	384	0	271	1,151	131	3,923		2	4	20	13
Peak Hour	0	67	39	44	0	163	41	145	0	39	510	204	0	144	586	64	2,046		0	4	10	10



(303) 216-2439
www.alltrafficdata.net

Location: 7 US 40 & JOHNS DR PM

Date: Saturday, July 13, 2019

Peak Hour: 04:15 PM - 05:15 PM

Peak 15-Minutes: 05:00 PM - 05:15 PM

Peak Hour - All Vehicles

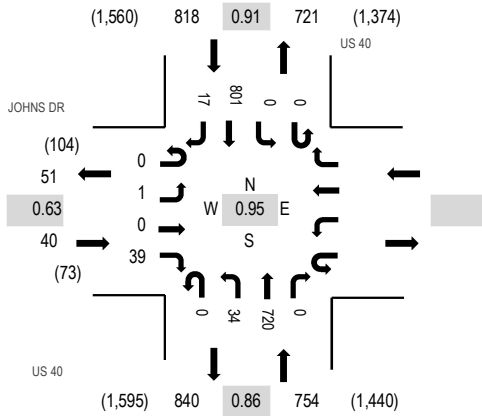

Note: Total study counts contained in parentheses.

Peak Hour - Pedestrians/Bicycles on Crosswalk

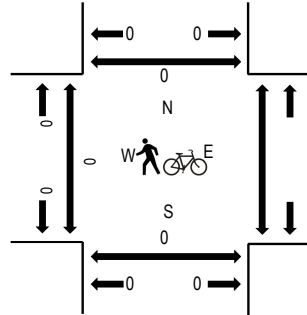

Traffic Counts

Interval Start Time	JOHNS DR Eastbound				Westbound			US 40 Northbound			US 40 Southbound				Total	Rolling Hour	Pedestrian Crossings				
	U-Turn	Left	Thru	Right	U-Turn	Left	Thru	Right	U-Turn	Left	Thru	Right	West	East			South	North			
4:00 PM	0	0	0	9					0	10	214	0	0	0	182	4	419	1,608	0	0	0
4:15 PM	0	0	0	10					0	12	180	0	0	0	179	5	386	1,612	0	0	0
4:30 PM	0	0	0	10					0	9	174	0	0	0	200	2	395	1,598	0	0	0
4:45 PM	0	0	0	4					0	7	167	0	0	0	223	7	408	1,543	0	0	0
5:00 PM	0	1	0	15					0	6	199	0	0	0	199	3	423	1,465	0	0	0
5:15 PM	0	0	0	6					0	12	153	0	0	0	195	6	372		0	0	0
5:30 PM	0	0	0	10					0	6	155	0	0	0	162	7	340		0	0	0
5:45 PM	0	0	0	8					0	5	131	0	0	0	183	3	330		0	0	0
Count Total	0	1	0	72					0	67	1,373	0	0	0	1,523	37	3,073		0	0	0
Peak Hour	0	1	0	39					0	34	720	0	0	0	801	17	1,612		0	0	0



(303) 216-2439
www.alltrafficdata.net

Location: 8 US 40 & OLD VICTORY RD PM
Date: Saturday, July 13, 2019
Peak Hour: 04:30 PM - 05:30 PM
Peak 15-Minutes: 04:45 PM - 05:00 PM

Peak Hour - All Vehicles

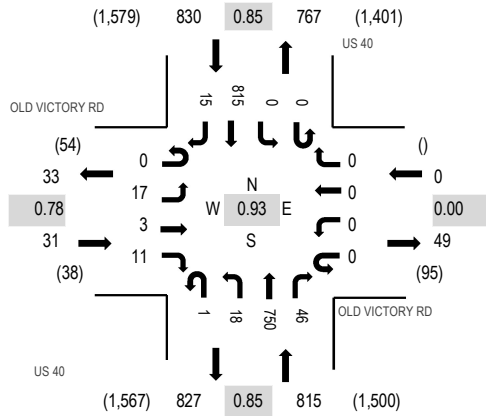

Peak Hour - Pedestrians/Bicycles on Crosswalk

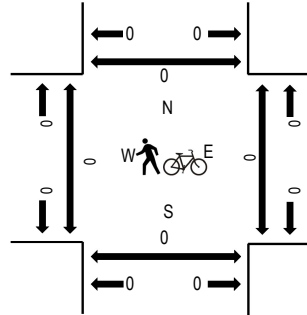

Note: Total study counts contained in parentheses.

Traffic Counts

Interval Start Time	OLD VICTORY RD Eastbound				OLD VICTORY RD Westbound				US 40 Northbound			US 40 Southbound				Total	Rolling Hour	Pedestrian Crossings				
	U-Turn	Left	Thru	Right	U-Turn	Left	Thru	Right	U-Turn	Left	Thru	Right	U-Turn	Left	Thru			Right	West	East	South	North
4:00 PM	0	1	1	1	0	0	0	0	0	5	164	14	0	0	162	5	353	1,639	0	0	0	0
4:15 PM	0	1	0	1	0	0	0	0	0	0	160	16	0	0	212	3	393	1,664	0	0	0	0
4:30 PM	0	4	1	5	0	0	0	0	0	3	175	11	0	0	237	7	443	1,676	0	0	0	0
4:45 PM	0	4	0	2	0	0	0	0	0	4	222	14	0	0	199	5	450	1,600	0	0	0	0
5:00 PM	0	5	1	2	0	0	0	0	0	7	179	13	0	0	170	1	378	1,478	0	0	0	0
5:15 PM	0	4	1	2	0	0	0	0	1	4	174	8	0	0	209	2	405		0	0	0	0
5:30 PM	0	0	1	0	0	0	0	0	0	3	162	7	0	0	192	2	367		0	0	0	0
5:45 PM	0	0	0	1	0	0	0	0	0	1	146	7	0	0	171	2	328		0	0	0	0
Count Total	0	19	5	14	0	0	0	0	1	27	1,382	90	0	0	1,552	27	3,117		0	0	0	0
Peak Hour	0	17	3	11	0	0	0	0	1	18	750	46	0	0	815	15	1,676		0	0	0	0



(303) 216-2439
www.alltrafficdata.net

Location: 9 US 40 & FIRE STATION ACCESS PM

Date: Saturday, July 13, 2019

Peak Hour: 04:00 PM - 05:00 PM

Peak 15-Minutes: 04:00 PM - 04:15 PM

Peak Hour - All Vehicles

Peak Hour - Pedestrians/Bicycles on Crosswalk

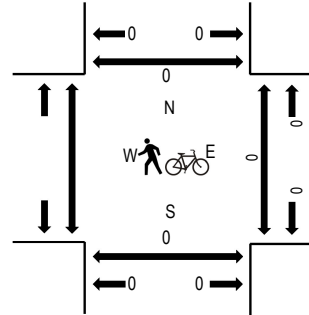
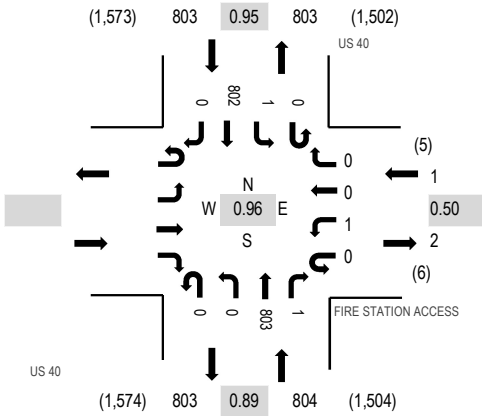

Note: Total study counts contained in parentheses.

Traffic Counts

Interval Start Time	FIRE STATION ACCESS				US 40 Northbound				US 40 Southbound				Total	Rolling Hour	Pedestrian Crossings						
	U-Turn	Left	Thru	Right	U-Turn	Left	Thru	Right	U-Turn	Left	Thru	Right			West	East	South	North			
4:00 PM					0	1	0	0	0	0	225	1	0	0	193	0	420	1,608	0	0	0
4:15 PM					0	0	0	0	0	0	211	0	0	0	173	0	384	1,600	0	0	0
4:30 PM					0	0	0	0	0	0	186	0	0	1	215	0	402	1,592	0	0	0
4:45 PM					0	0	0	0	0	0	181	0	0	0	221	0	402	1,548	0	0	0
5:00 PM					0	0	0	1	0	0	206	0	1	0	204	0	412	1,474	0	0	0
5:15 PM					0	0	0	0	0	0	178	0	0	0	198	0	376		0	0	0
5:30 PM					0	1	0	0	0	0	169	2	0	0	186	0	358		0	0	0
5:45 PM					0	2	0	0	0	0	144	1	0	1	180	0	328		0	0	0
Count Total					0	4	0	1	0	0	1,500	4	1	2	1,570	0	3,082		0	0	0
Peak Hour					0	1	0	0	0	0	803	1	0	1	802	0	1,608		0	0	0



(303) 216-2439
www.alltrafficdata.net

Location: 10 US 40 & RENDEZVOUS RD PM
Date: Saturday, July 13, 2019
Peak Hour: 04:00 PM - 05:00 PM
Peak 15-Minutes: 04:00 PM - 04:15 PM

Peak Hour - All Vehicles

Peak Hour - Pedestrians/Bicycles on Crosswalk

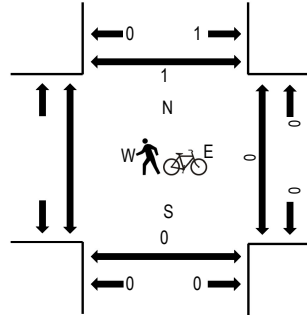
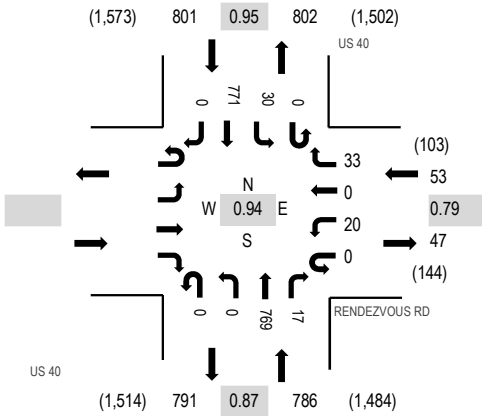

Note: Total study counts contained in parentheses.

Traffic Counts

Interval Start Time	RENDEZVOUS RD				US 40				US 40				Total	Rolling Hour	Pedestrian Crossings					
	Eastbound		Westbound		Northbound		Southbound		U-Turn	Left	Thru	Right			West	East	South	North		
4:00 PM				0	6	0	8	0					0	220					6	0
4:15 PM				0	3	0	5	0	0	208	3	0	10	165	0	394	1,625	0	0	0
4:30 PM				0	5	0	8	0	0	174	4	0	8	205	0	404	1,634	0	0	0
4:45 PM				0	6	0	12	0	0	167	4	0	9	210	0	408	1,592	0	0	0
5:00 PM				0	1	0	9	0	0	197	9	0	13	190	0	419	1,520	0	0	0
5:15 PM				0	7	0	12	0	0	170	14	0	32	168	0	403		0	0	0
5:30 PM				0	5	0	5	0	0	166	3	0	11	172	0	362		0	0	0
5:45 PM				0	5	0	6	0	0	135	4	0	11	175	0	336		0	0	0
Count Total				0	38	0	65	0	0	1,437	47	0	97	1,476	0	3,160		0	0	0
Peak Hour				0	20	0	33	0	0	769	17	0	30	771	0	1,640		0	0	0



(303) 216-2439
www.alltrafficdata.net

Location: 3 CR 72 & US 40 Noon
Date: Saturday, January 18, 2020
Peak Hour: 12:00 PM - 01:00 PM
Peak 15-Minutes: 12:45 PM - 01:00 PM

Peak Hour - All Vehicles

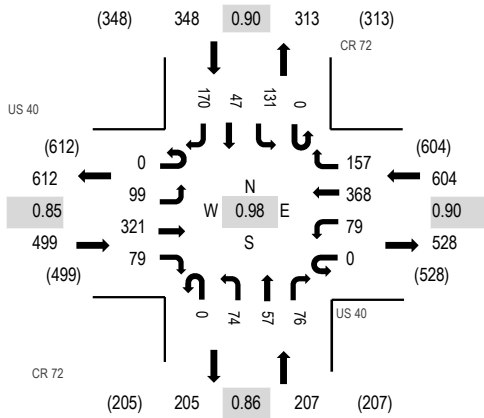

Note: Total study counts contained in parentheses.

Peak Hour - Pedestrians/Bicycles on Crosswalk

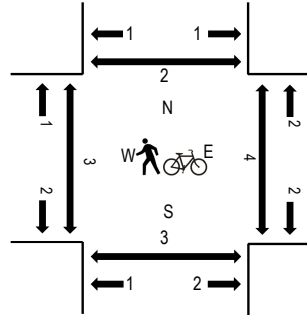

Traffic Counts

Interval Start Time	US 40 Eastbound				US 40 Westbound				CR 72 Northbound			CR 72 Southbound				Total	Rolling Hour	Pedestrian Crossings				
	U-Turn	Left	Thru	Right	U-Turn	Left	Thru	Right	U-Turn	Left	Thru	Right	U-Turn	Left	Thru			Right	West	East	South	North
12:00 PM	0	24	88	34	0	12	91	32	0	14	8	12	0	31	13	53	412	1,658	1	2	0	1
12:15 PM	0	27	82	18	0	20	96	32	0	15	18	21	0	30	14	39	412		0	1	1	1
12:30 PM	0	21	70	8	0	25	94	48	0	23	15	22	0	38	13	35	412		1	0	0	0
12:45 PM	0	27	81	19	0	22	87	45	0	22	16	21	0	32	7	43	422		1	1	2	0
Count Total	0	99	321	79	0	79	368	157	0	74	57	76	0	131	47	170	1,658		3	4	3	2
Peak Hour	0	99	321	79	0	79	368	157	0	74	57	76	0	131	47	170	1,658		3	4	3	2



(303) 216-2439
www.alltrafficdata.net

Location: 4 CR 804 & SAFEWAY ACCESS Noon

Date: Saturday, January 18, 2020

Peak Hour: 12:00 PM - 01:00 PM

Peak 15-Minutes: 12:45 PM - 01:00 PM

Peak Hour - All Vehicles

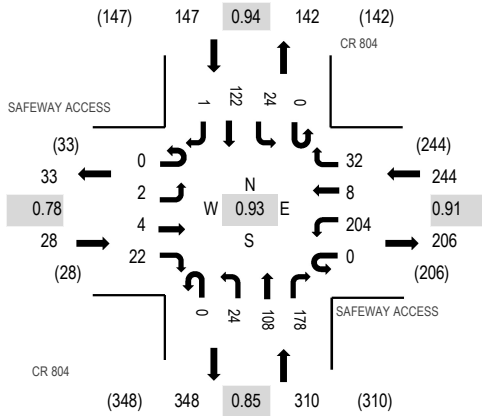

Peak Hour - Pedestrians/Bicycles on Crosswalk

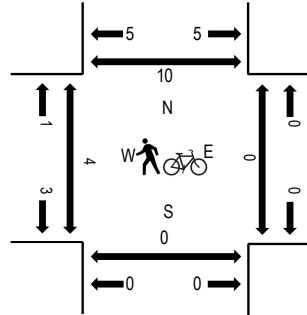

Note: Total study counts contained in parentheses.

Traffic Counts

Interval Start Time	SAFEMAY ACCESS Eastbound				SAFEMAY ACCESS Westbound				CR 804 Northbound			CR 804 Southbound				Total	Rolling Hour	Pedestrian Crossings				
	U-Turn	Left	Thru	Right	U-Turn	Left	Thru	Right	U-Turn	Left	Thru	Right	U-Turn	Left	Thru			Right	West	East	South	North
12:00 PM	0	1	1	7	0	59	1	7	0	4	23	35	0	7	28	0	173	729	1	0	0	2
12:15 PM	0	0	1	5	0	44	1	8	0	5	23	47	0	4	33	1	172		1	0	0	7
12:30 PM	0	1	2	3	0	53	2	9	0	9	25	48	0	5	30	0	187		2	0	0	1
12:45 PM	0	0	0	7	0	48	4	8	0	6	37	48	0	8	31	0	197		0	0	0	0
Count Total	0	2	4	22	0	204	8	32	0	24	108	178	0	24	122	1	729		4	0	0	10
Peak Hour	0	2	4	22	0	204	8	32	0	24	108	178	0	24	122	1	729		4	0	0	10